

CATALOG# : _____

PROJECT : _____

TYPE : _____

Series HSL BOLP

LED Commercial Grade Bollard

This attractive, newly redesigned heavy-duty bollard features full proof aluminum construction housing, providing corrosion and vandal resistance ideal for lighting pedestrian walkways, as well as accenting the exterior grounds of office and apartment buildings, hotel and parks. A solid foundation withstands the elements, driver options work in even the worst weather conditions.

CONSTRUCTION

LED compartment is airtight to prevent fogging and condensation build up and keep water out. Aluminum reflector designed to reduce glare and produce an even distribution. Extruded aluminum tube provides as well as protects and conceals the component wiring. Clear UV resistant polycarbonate lens allows for optimal light transmission and protects the light engine compartment from harsh environments.



DIMENSIONS

Diameter: 8"

Height: 36"

FEATURES & BENEFITS

- Housing is consisting of an extruded aluminum alloy body standard 4kV surge
- High-impact polycarbonate diffuser
- UV stabilized powder coated finish
- Working temperature: -40C ~ + 50C
- 5 Year Warranty

CATALOG# : _____

PROJECT : _____

TYPE : _____

Series HSL BOLP

LED Commercial Grade Bollard

DRAWINGS & IMAGES

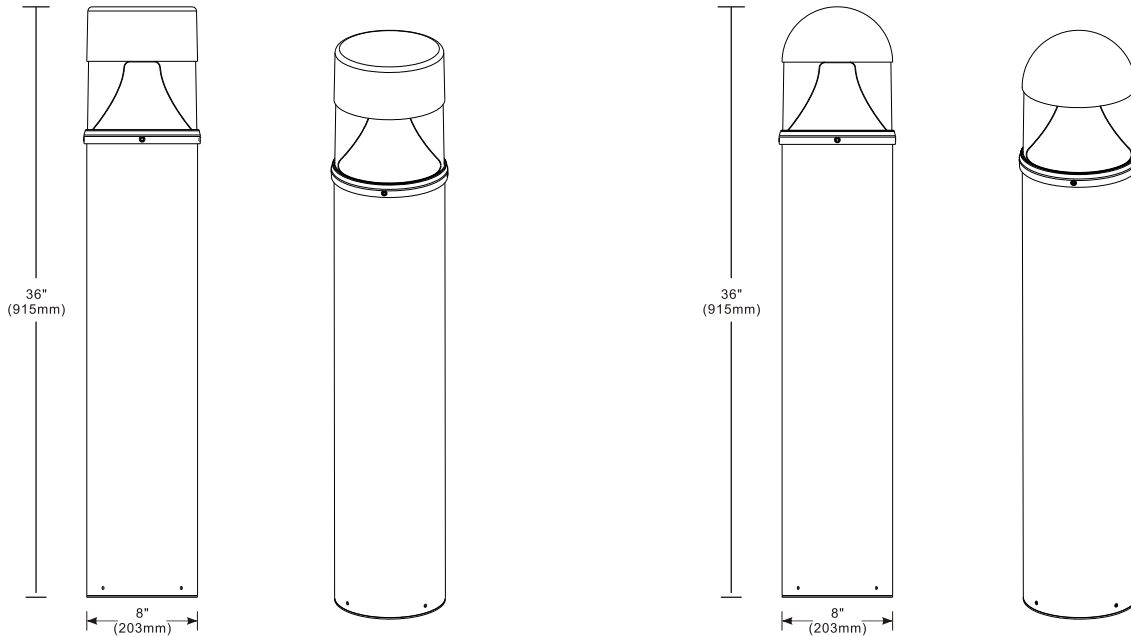

Versatile mounting holes

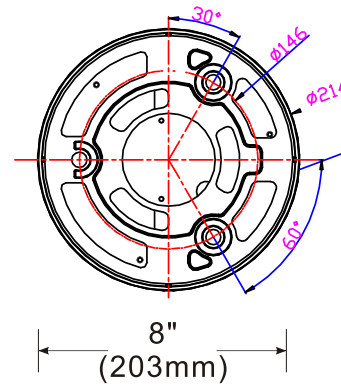

PRODUCT NUMBERS

ITEM NUMBER	DESCRIPTION
HSLBOLPF18W2000LMV40KBZ	LED Flat Top Bollard 18W 2035lm 4000K 120V-277V Bronze Finish
HSLBOLPF18W2000LMV50KBZ	LED Flat Top Bollard 18W 2035lm 5000K 120V-277V Bronze Finish
HSLBOLPR18W2000LMV40KBZ	LED Flat Round Bollard 18W 2035lm 4000K 120V-277V Bronze Finish
HSLBOLPR18W2000LMV50KBZ	LED Flat Round Bollard 18W 2035lm 5000K 120V-277V Bronze Finish