

HSL RELZXTE RECESSED ALUMINUM LED EDGELIT EXIT SIGN

STANDARD

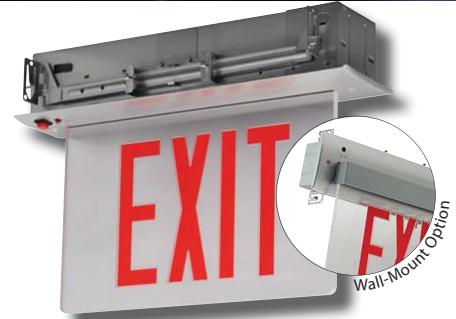

OPTIONAL



ILLUMINATION

- Ultra bright, energy efficient, long life Red or Green LED.
- UV-stabilized ultra-clear acrylic edgelit panel provides consistent, uniform illumination.
- Double face utilizes factory installed silver or white mylar background panel.

ELECTRICAL

- Dual 120/277 voltage standard. Optional multi-tap 208/220/240 voltage available.
- Charge rate/power "ON" LED indicator light and push-to-test switch for mandated code compliance testing.
- 4.8V long life, maintenance-free, rechargeable NiCd battery.
- Internal solid-state transfer switch automatically connects the internal battery to LED board for minimum 90-minute emergency illumination.
- Fully automatic solid-state, two rate charger initiates battery charging to recharge a discharged battery in 24 hours.

MOUNTING

- Compatible with drywall or drop ceiling mount installations. Bar hangers included.
- Wall mount capability optional.

HOUSING

- Premium-grade, extruded aluminum housing.
- Extruded aluminum trim assembly is easily detachable from below, providing accessibility for service or maintenance. Available in black or white powder-coated finishes.
- Self-adhesive chevron appliques and guide template provided for directional indication.

OPTIONS

- SDT: Self-diagnostic feature performs monthly, biannual, and annual tests to ensure reliable operation and meet electrical and life safety codes.
- 2C: Dual circuit option on the AC-only unit enables it to be connected to two different (one acting as a back-up to the other) supplies at the same time.
- Custom: Signs available with requested 'special' wording.
- USA: Substantial transformation assembly in the U.S. complies with "Assembled in the USA" under the Buy American Act.
- SPV: UL Listed for special voltage option.
- WM: Allows for the unit to be wall recessed mounted.

WARRANTY / LISTING

- Five year warranty on all electronics and housing. Battery pro rated for five years.
- Meets UL924, NFPA 101 Life Safety Code, NEC, OSHA, Local and State Codes.
- UL Listed for damp locations (0°C – 50°C).

DIMENSIONS

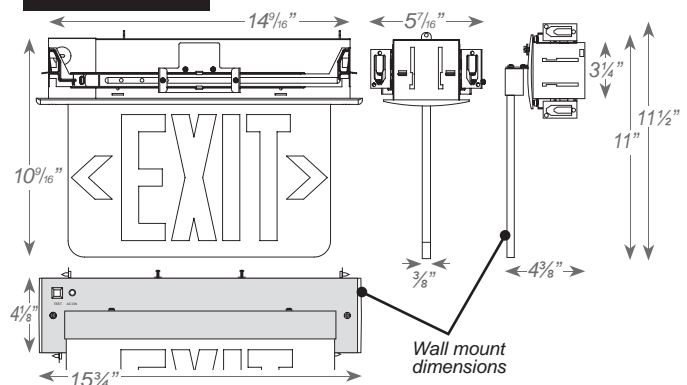

Sample Part Number: HSL RELZXTE-1-R-C-W-EM-USA

ORDERING INFORMATION

MODEL	No. of FACES	LETTER	PANEL	TRIM PLATE	BATTERY	OPTIONS
HSL RELZXTE	1	Single Face	R Red	C Clear ¹	W White	Blank
	2	Double Face	G Green	M Mirror	B Black	EM
			W White	A Aluminum		
					AC Only	Custom
					Battery Backup	USA
						SDT
						2C
						SPV
						WM

Notes:

1. With Single face only
2. Not available with SDT
3. Available only with EM units
4. Available only with AC units